

Battery Chargers

ABCM Battery Charger

Modular design

Ethernet connection

Wide temperature compensation -10°C to 60°C^*

Australian designed and manufactured



AMPCONTROL[®]

ABCM Battery Charger

Ampcontrol's ABCM Battery Charger range offers the latest switched mode rectifier design, providing a highly stable output voltage and current limiting. The range includes a microprocessor controlled rectifier unit which offers improved efficiency over the single phase full wave thyristor controlled rectifier units, as well as modularity and redundancy.

All relevant parameters are digitally stored in non-volatile RAM to maintain the charger configuration even with loss of power. The DC output is fully regulated, short circuit protected and monitored against over and under voltage with current limit.

This cost effective system is easy to use and set up.

Features:

- Suitable for sealed lead acid batteries and can also be used for NiCad and Lithium batteries
- Ethernet connection for remote or local monitoring and control via web browser
- Modular design
- Wide temperature compensation -10°C to 60°C*
- Range - 12 to 120V DC, 5Amps to >100Amps output
- LCD comprehensive monitoring for metering, alarm messages and parameter settings
- Four relay outputs providing indication for normal and alarm status and can be customised if required
- Manual, automatic and timed boost charge modes are available
- Efficiency of the switched mode model is at least 20% better than transformer/choke units

Application:

Ideally suited for auto charging of stand-by battery supplies where a constant voltage, current limited charging characteristic is desired including:

- Emergency lighting
- Switchgear control
- DC supplies

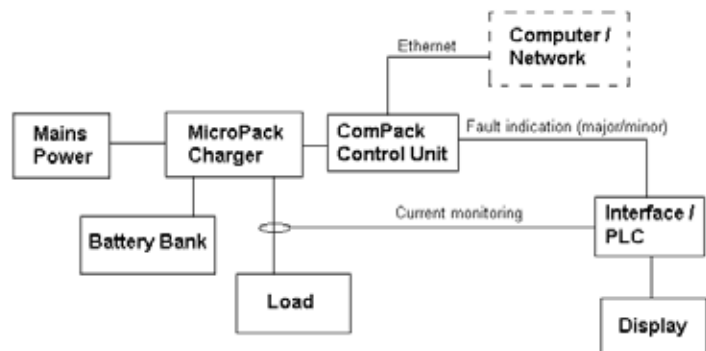

The ABCM Battery Charger is available with a range of options that include battery voltage, battery capacity, face mounted displays and others.

* battery dependent

AMPCONTROL ELECTRONICS

Ampcontrol CSM ABN 35 000 770 141
7 Billbrooke Close CAMERON PARK NSW 2285

Phone: +61 2 4903 4800

Fax: +61 2 4903 4888

electronics@ampcontrolgroup.com

ampcontrolgroup.com